

# DATA SHEET

**74LVC1G06**

**Inverter with open-drain output**

Product specification  
Supersedes data of 2002 May 29

2003 Mar 03

## Inverter with open-drain output

## 74LVC1G06

## FEATURES

- Wide supply voltage range from 1.65 to 5.5 V
- High noise immunity
- Complies with JEDEC standard:
  - JESD8-7 (1.65 to 1.95 V)
  - JESD8-5 (2.3 to 2.7 V)
  - JESD8B/JESD36 (2.7 to 3.6 V)
- $\pm 24$  mA output drive ( $V_{CC} = 3.0$  V)
- CMOS low power consumption
- Latch-up performance exceeds 250 mA
- Direct interface with TTL levels
- Inputs accept voltages up to 5 V
- Multiple package options
- ESD protection:
  - HBM EIA/JESD22-A114-A exceeds 2000 V
  - MM EIA/JESD22-A115-A exceeds 200 V.
- Specified from  $-40$  to  $+125$  °C.

## DESCRIPTION

The 74LVC1G06 is a high-performance, low-power, low-voltage, Si-gate CMOS device, superior to most advanced CMOS compatible TTL families.

Input can be driven from either 3.3 or 5 V devices. These features allow the use of these devices in a mixed 3.3 and 5 V environment.

Schmitt trigger action at all inputs makes the circuit tolerant for slower input rise and fall time.

This device is fully specified for partial power-down applications using  $I_{off}$ . The  $I_{off}$  circuitry disables the output, preventing the damaging backflow current through the device when it is powered down.

The 74LVC1G06 provides the inverting buffer.

The output of the device is an open drain and can be connected to other open-drain outputs to implement active-LOW wired-OR or active-HIGH wired-AND functions.

## QUICK REFERENCE DATA

GND = 0 V;  $T_{amb} = 25$  °C;  $t_r = t_f \leq 2.5$  ns.

SYMBOL	PARAMETER	CONDITIONS	TYPICAL	UNIT
$t_{PHL}/t_{PLH}$	propagation delay inputs A to output Y	$V_{CC} = 1.8$ V; $C_L = 30$ pF; $R_L = 1$ k $\Omega$	3	ns
		$V_{CC} = 2.5$ V; $C_L = 30$ pF; $R_L = 500$ $\Omega$	1.9	ns
		$V_{CC} = 2.7$ V; $C_L = 50$ pF; $R_L = 500$ $\Omega$	2.5	ns
		$V_{CC} = 3.3$ V; $C_L = 50$ pF; $R_L = 500$ $\Omega$	2.3	ns
		$V_{CC} = 5.0$ V; $C_L = 50$ pF; $R_L = 500$ $\Omega$	1.7	ns
$C_I$	input capacitance		5	pF
$C_{PD}$	power dissipation capacitance per buffer	$V_{CC} = 3.3$ V; notes 1 and 2	6	pF

## Notes

1.  $C_{PD}$  is used to determine the dynamic power dissipation ( $P_D$  in  $\mu$ W).

$$P_D = C_{PD} \times V_{CC}^2 \times f_i \times N + \Sigma(C_L \times V_{CC}^2 \times f_o) \text{ where:}$$

$f_i$  = input frequency in MHz;

$f_o$  = output frequency in MHz;

$C_L$  = output load capacitance in pF;

$V_{CC}$  = supply voltage in Volts;

$N$  = total load switching outputs;

$\Sigma(C_L \times V_{CC}^2 \times f_o)$  = sum of the outputs.

2. The condition is  $V_I = \text{GND}$  to  $V_{CC}$ .

# Inverter with open-drain output

# 74LVC1G06

## FUNCTION TABLE

See note 1.

INPUT	OUTPUT
A	Y
L	Z
H	L

### Note

- 1. H = HIGH voltage level;
- L = LOW voltage level;
- Z = high-impedance OFF-state.

## ORDERING INFORMATION

TYPE NUMBER	PACKAGE					
	TEMPERATURE RANGE	PINS	PACKAGE	MATERIAL	CODE	MARKING
74LVC1G06GW	-40 to +125 °C	5	SC-88A	plastic	SOT353	VR
74LVC1G06GV	-40 to +125 °C	5	SC-74A	plastic	SOT753	V06

## PINNING

PIN	SYMBOL	DESCRIPTION
1	n.c.	not connected
2	A	data input A
3	GND	ground (0 V)
4	Y	data output Y
5	V <sub>CC</sub>	supply voltage

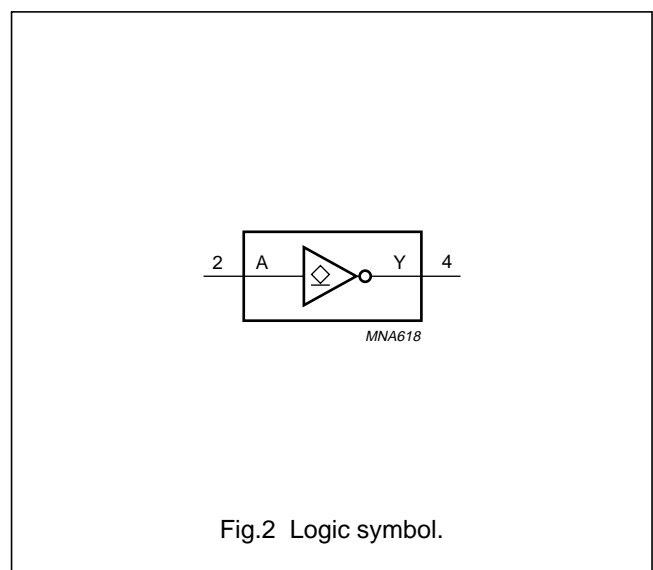
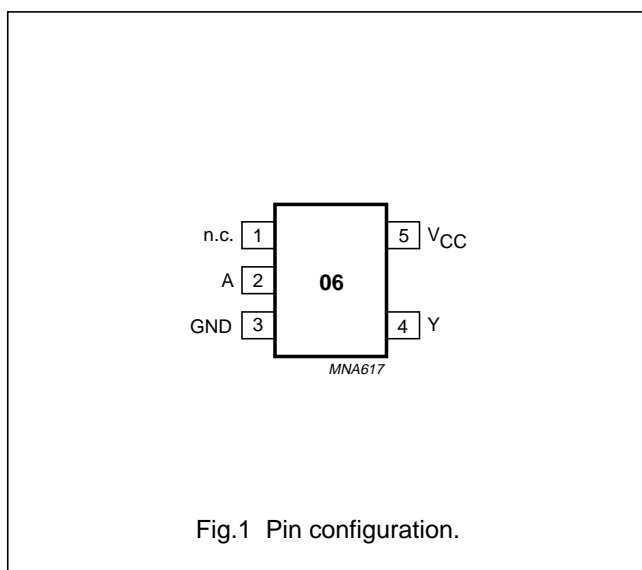

Inverter with open-drain output

74LVC1G06

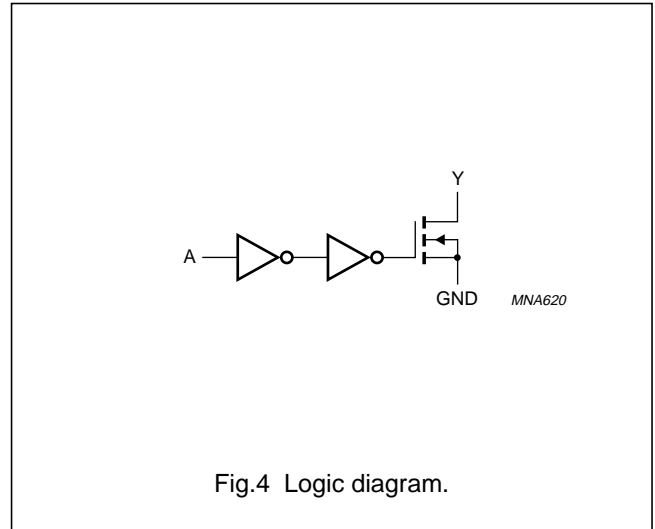
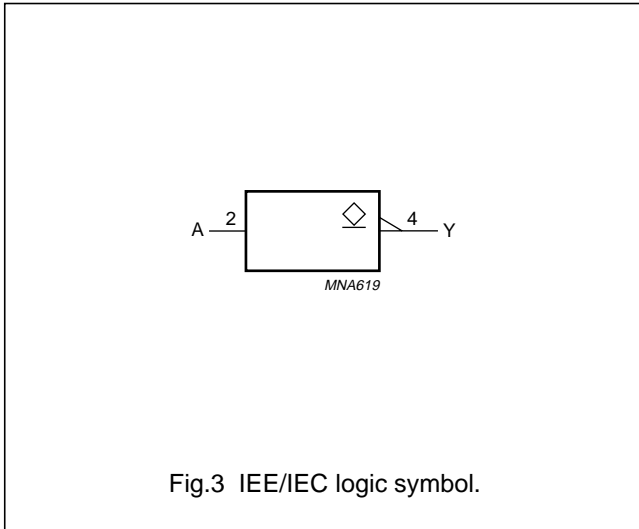

RECOMMENDED OPERATING CONDITIONS

SYMBOL	PARAMETER	CONDITIONS	MIN.	MAX.	UNIT
$V_{CC}$	supply voltage		1.65	5.5	V
$V_I$	input voltage		0	5.5	V
$V_O$	output voltage	active mode	0	5.5	V
		$V_{CC} = 0$ V; Power-down mode	0	5.5	V
$T_{amb}$	operating ambient temperature		-40	+125	°C
$t_r, t_f$	input rise and fall times	$V_{CC} = 1.65$ to $2.7$ V	0	20	ns/V
		$V_{CC} = 2.7$ to $5.5$ V	0	10	ns/V

LIMITING VALUES

In accordance with the Absolute Maximum Rating System (IEC 60134); voltages are referenced to GND (ground = 0 V).

SYMBOL	PARAMETER	CONDITIONS	MIN.	MAX.	UNIT
$V_{CC}$	supply voltage		-0.5	+6.5	V
$I_{IK}$	input diode current	$V_I < 0$	-	-50	mA
$V_I$	input voltage	note 1	-0.5	+6.5	V
$I_{OK}$	output diode current	$V_O > V_{CC}$ or $V_O < 0$	-	±50	mA
$V_O$	output voltage	active mode; notes 1 and 2	-0.5	+6.5	V
		Power-down mode; notes 1 and 2	-0.5	+6.5	V
$I_O$	output source or sink current	$V_O = 0$ to $V_{CC}$	-	±50	mA
$I_{CC}, I_{GND}$	$V_{CC}$ or GND current		-	±100	mA
$T_{stg}$	storage temperature		-65	+150	°C
$P_D$	power dissipation per package	for temperature range from -40 to +125 °C	-	250	mW

Notes

1. The input and output voltage ratings may be exceeded if the input and output current ratings are observed.
2. When  $V_{CC} = 0$  V (Power-down mode), the output voltage can be 5.5 V in normal operation.

## Inverter with open-drain output

## 74LVC1G06

## DC CHARACTERISTICS

At recommended operating conditions; voltages are referenced to GND (ground = 0 V).

SYMBOL	PARAMETER	TEST CONDITIONS		MIN.	TYP. <sup>(1)</sup>	MAX.	UNIT
		OTHER	V <sub>CC</sub> (V)				
<b>T<sub>amb</sub> = -40 to +85 °C</b>							
V <sub>IH</sub>	HIGH-level input voltage		1.65 to 1.95	0.65 × V <sub>CC</sub>	–	–	V
			2.3 to 2.7	1.7	–	–	V
			2.7 to 3.6	2.0	–	–	V
			4.5 to 5.5	0.7 × V <sub>CC</sub>	–	–	V
V <sub>IL</sub>	LOW-level input voltage		1.65 to 1.95	–	–	0.35 × V <sub>CC</sub>	V
			2.3 to 2.7	–	–	0.7	V
			2.7 to 3.6	–	–	0.8	V
			4.5 to 5.5	–	–	0.3 × V <sub>CC</sub>	V
V <sub>OL</sub>	LOW-level output voltage	V <sub>I</sub> = V <sub>IH</sub> or V <sub>IL</sub> I <sub>O</sub> = 100 μA	1.65 to 5.5	–	–	0.1	V
		I <sub>O</sub> = 4 mA	1.65	–	–	0.45	V
		I <sub>O</sub> = 8 mA	2.3	–	–	0.3	V
		I <sub>O</sub> = 12 mA	2.7	–	–	0.4	V
		I <sub>O</sub> = 24 mA	3.0	–	–	0.55	V
		I <sub>O</sub> = 32 mA	4.5	–	–	0.55	V
I <sub>LI</sub>	input leakage current	V <sub>I</sub> = 5.5 V or GND	5.5	–	±0.1	±5	μA
I <sub>off</sub>	power OFF leakage current	V <sub>I</sub> or V <sub>O</sub> = 5.5 V	0	–	±0.1	±10	μA
I <sub>CC</sub>	quiescent supply current	V <sub>I</sub> = V <sub>CC</sub> or GND; I <sub>O</sub> = 0	5.5	–	0.1	10	μA
ΔI <sub>CC</sub>	additional quiescent supply current per pin	V <sub>I</sub> = V <sub>CC</sub> – 0.6 V; I <sub>O</sub> = 0	2.3 to 5.5	–	5	500	μA

## Inverter with open-drain output

## 74LVC1G06

SYMBOL	PARAMETER	TEST CONDITIONS		MIN.	TYP. <sup>(1)</sup>	MAX.	UNIT
		OTHER	V <sub>CC</sub> (V)				
<b>T<sub>amb</sub> = -40 to +125 °C</b>							
V <sub>IH</sub>	HIGH-level input voltage		1.65 to 1.95	0.65 × V <sub>CC</sub>	–	–	V
			2.3 to 2.7	1.7	–	–	V
			2.7 to 3.6	2.0	–	–	V
			4.5 to 5.5	0.7 × V <sub>CC</sub>	–	–	V
V <sub>IL</sub>	LOW-level input voltage		1.65 to 1.95	–	–	0.35 × V <sub>CC</sub>	V
			2.3 to 2.7	–	–	0.7	V
			2.7 to 3.6	–	–	0.8	V
			4.5 to 5.5	–	–	0.3 × V <sub>CC</sub>	V
V <sub>OL</sub>	LOW-level output voltage	V <sub>I</sub> = V <sub>IH</sub> or V <sub>IL</sub> I <sub>O</sub> = 100 μA	1.65 to 5.5	–	–	0.1	V
		I <sub>O</sub> = 4 mA	1.65	–	–	0.70	V
		I <sub>O</sub> = 8 mA	2.3	–	–	0.45	V
		I <sub>O</sub> = 12 mA	2.7	–	–	0.60	V
		I <sub>O</sub> = 24 mA	3.0	–	–	0.80	V
		I <sub>O</sub> = 32 mA	4.5	–	–	0.80	V
I <sub>LI</sub>	input leakage current	V <sub>I</sub> = 5.5 V or GND	5.5	–	–	±100	μA
I <sub>off</sub>	power OFF leakage current	V <sub>I</sub> or V <sub>O</sub> = 5.5 V	0	–	–	±200	μA
I <sub>CC</sub>	quiescent supply current	V <sub>I</sub> = V <sub>CC</sub> or GND; I <sub>O</sub> = 0	5.5	–	–	200	μA
ΔI <sub>CC</sub>	additional quiescent supply current per pin	V <sub>I</sub> = V <sub>CC</sub> – 0.6 V; I <sub>O</sub> = 0	2.3 to 5.5	–	–	5000	μA

**Note**

1. All typical values are measured at V<sub>CC</sub> = 3.3 V and T<sub>amb</sub> = 25 °C.

## Inverter with open-drain output

## 74LVC1G06

**AC CHARACTERISTICS**GND = 0 V;  $t_r = t_f \leq 2.0$  ns.

SYMBOL	PARAMETER	TEST CONDITIONS		MIN.	TYP.	MAX.	UNIT
		WAVEFORMS	V <sub>CC</sub> (V)				
<b>T<sub>amb</sub> = -40 to +85 °C</b>							
t <sub>PHL</sub> /t <sub>PLH</sub>	propagation delay A to Y	see Figs 5 and 6	1.65 to 1.95	1.0	3	6.5	ns
			2.3 to 2.7	0.5	1.9	4	ns
			2.7	0.5	2.5	4.5	ns
			3.0 to 3.6	0.5	2.3	4	ns
			4.5 to 5.5	0.5	1.7	3	ns
<b>T<sub>amb</sub> = -40 to +125 °C</b>							
t <sub>PHL</sub> /t <sub>PLH</sub>	propagation delay A to Y	see Figs 5 and 6	1.65 to 1.95	1.0	–	8.5	ns
			2.3 to 2.7	0.5	–	5.5	ns
			2.7	0.5	–	6	ns
			3.0 to 3.6	0.5	–	5.5	ns
			4.5 to 5.5	0.5	–	4	ns

Inverter with open-drain output

74LVC1G06

AC WAVEFORMS

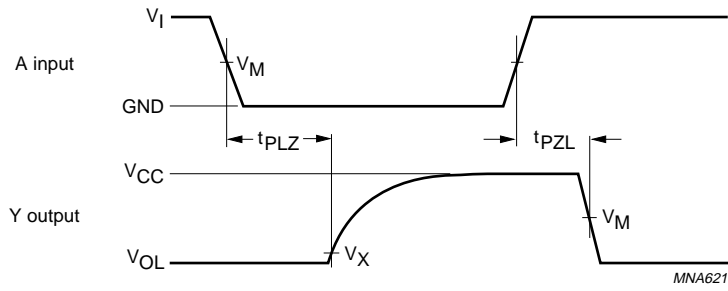

V <sub>CC</sub>	V <sub>M</sub>	V <sub>X</sub>	V <sub>I</sub>
1.65 to 1.95 V	0.5 × V <sub>CC</sub>	V <sub>OL</sub> + 0.15 V	V <sub>CC</sub>
2.3 to 2.7 V	0.5 × V <sub>CC</sub>	V <sub>OL</sub> + 0.15 V	V <sub>CC</sub>
2.7 V	1.5 V	V <sub>OL</sub> + 0.3 V	2.7 V
3.0 to 3.6 V	1.5 V	V <sub>OL</sub> + 0.3 V	2.7 V
4.5 to 5.5 V	0.5 × V <sub>CC</sub>	V <sub>OL</sub> + 0.3 V	V <sub>CC</sub>

Fig.5 Input A to output Y propagation delay times.



Inverter with open-drain output

74LVC1G06

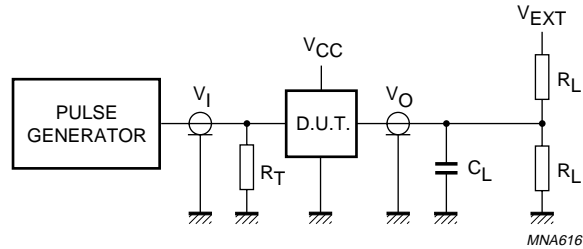

V <sub>CC</sub>	V <sub>I</sub>	C <sub>L</sub>	R <sub>L</sub>	V <sub>EXT</sub>		
				t <sub>PLH</sub> /t <sub>PHL</sub>	t <sub>PZH</sub> /t <sub>PHZ</sub>	t <sub>PZL</sub> /t <sub>PLZ</sub>
1.65 to 1.95 V	V <sub>CC</sub>	30 pF	1 kΩ	open	GND	2 × V <sub>CC</sub>
2.3 to 2.7 V	V <sub>CC</sub>	30 pF	500 Ω	open	GND	2 × V <sub>CC</sub>
2.7 V	2.7 V	50 pF	500 Ω	open	GND	6 V
3.0 to 3.6 V	2.7 V	50 pF	500 Ω	open	GND	6 V
4.5 to 5.5 V	V <sub>CC</sub>	50 pF	500 Ω	open	GND	2 × V <sub>CC</sub>

Definitions for test circuit:

R<sub>L</sub> = Load resistor.

C<sub>L</sub> = Load capacitance including jig and probe capacitance.

R<sub>T</sub> = Termination resistance should be equal to the output impedance Z<sub>o</sub> of the pulse generator.

Fig.6 Load circuitry for switching times.

Inverter with open-drain output

74LVC1G06

PACKAGE OUTLINES

Plastic surface mounted package; 5 leads

SOT353

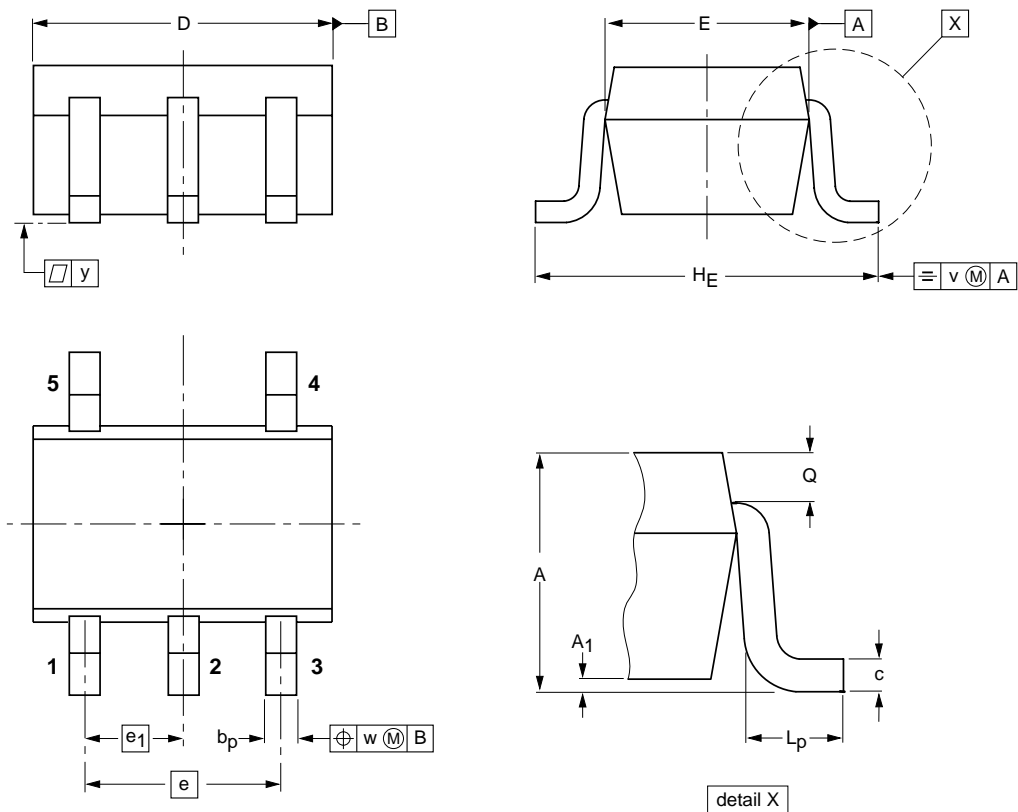

DIMENSIONS (mm are the original dimensions)

UNIT	A	A <sub>1</sub> max	b <sub>p</sub>	c	D	E <sup>(2)</sup>	e	e <sub>1</sub>	H <sub>E</sub>	L <sub>p</sub>	Q	v	w	y
mm	1.1 0.8	0.1	0.30 0.20	0.25 0.10	2.2 1.8	1.35 1.15	1.3	0.65	2.2 2.0	0.45 0.15	0.25 0.15	0.2	0.2	0.1

OUTLINE VERSION	REFERENCES				EUROPEAN PROJECTION	ISSUE DATE
	IEC	JEDEC	EIAJ			
SOT353			SC-88A			97-02-28

Inverter with open-drain output

74LVC1G06

Plastic surface mounted package; 5 leads

SOT753

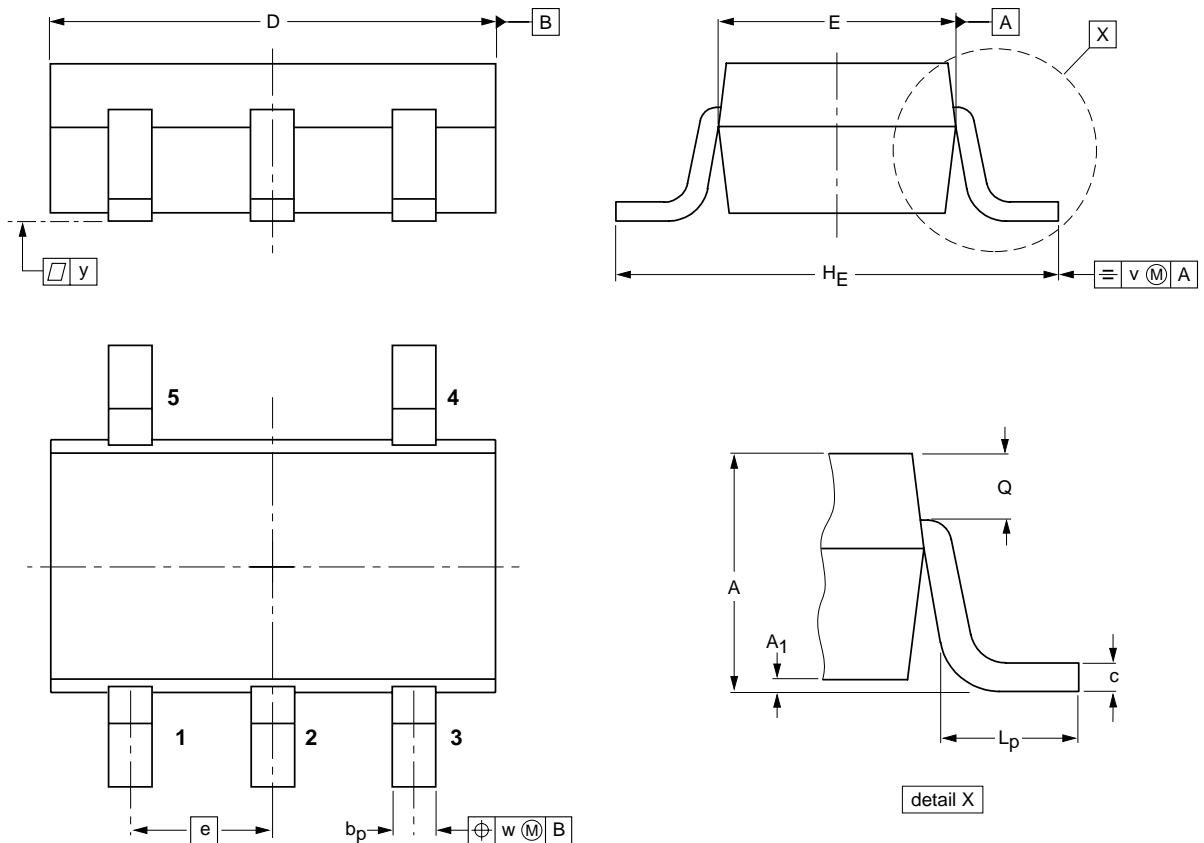

DIMENSIONS (mm are the original dimensions)

UNIT	A	A <sub>1</sub>	b <sub>p</sub>	c	D	E	e	H <sub>E</sub>	L <sub>p</sub>	Q	v	w	y
mm	1.1 0.9	0.100 0.013	0.40 0.25	0.26 0.10	3.1 2.7	1.7 1.3	0.95	3.0 2.5	0.6 0.2	0.33 0.23	0.2	0.2	0.1

OUTLINE VERSION	REFERENCES				EUROPEAN PROJECTION	ISSUE DATE
	IEC	JEDEC	JEITA			
SOT753			SC-74A			02-04-16

## Inverter with open-drain output

## 74LVC1G06

### SOLDERING

#### Introduction to soldering surface mount packages

This text gives a very brief insight to a complex technology. A more in-depth account of soldering ICs can be found in our *"Data Handbook IC26; Integrated Circuit Packages"* (document order number 9398 652 90011).

There is no soldering method that is ideal for all surface mount IC packages. Wave soldering can still be used for certain surface mount ICs, but it is not suitable for fine pitch SMDs. In these situations reflow soldering is recommended.

#### Reflow soldering

Reflow soldering requires solder paste (a suspension of fine solder particles, flux and binding agent) to be applied to the printed-circuit board by screen printing, stencilling or pressure-syringe dispensing before package placement.

Several methods exist for reflowing; for example, convection or convection/infrared heating in a conveyor type oven. Throughput times (preheating, soldering and cooling) vary between 100 and 200 seconds depending on heating method.

Typical reflow peak temperatures range from 215 to 250 °C. The top-surface temperature of the packages should preferably be kept:

- below 220 °C for all the BGA packages and packages with a thickness  $\geq 2.5$  mm and packages with a thickness  $< 2.5$  mm and a volume  $\geq 350$  mm<sup>3</sup> so called thick/large packages
- below 235 °C for packages with a thickness  $< 2.5$  mm and a volume  $< 350$  mm<sup>3</sup> so called small/thin packages.

#### Wave soldering

Conventional single wave soldering is not recommended for surface mount devices (SMDs) or printed-circuit boards with a high component density, as solder bridging and non-wetting can present major problems.

To overcome these problems the double-wave soldering method was specifically developed.

If wave soldering is used the following conditions must be observed for optimal results:

- Use a double-wave soldering method comprising a turbulent wave with high upward pressure followed by a smooth laminar wave.
- For packages with leads on two sides and a pitch (e):
  - larger than or equal to 1.27 mm, the footprint longitudinal axis is **preferred** to be parallel to the transport direction of the printed-circuit board;
  - smaller than 1.27 mm, the footprint longitudinal axis **must** be parallel to the transport direction of the printed-circuit board.

The footprint must incorporate solder thieves at the downstream end.

- For packages with leads on four sides, the footprint must be placed at a 45° angle to the transport direction of the printed-circuit board. The footprint must incorporate solder thieves downstream and at the side corners.

During placement and before soldering, the package must be fixed with a droplet of adhesive. The adhesive can be applied by screen printing, pin transfer or syringe dispensing. The package can be soldered after the adhesive is cured.

Typical dwell time is 4 seconds at 250 °C.

A mildly-activated flux will eliminate the need for removal of corrosive residues in most applications.

#### Manual soldering

Fix the component by first soldering two diagonally-opposite end leads. Use a low voltage (24 V or less) soldering iron applied to the flat part of the lead. Contact time must be limited to 10 seconds at up to 300 °C.

When using a dedicated tool, all other leads can be soldered in one operation within 2 to 5 seconds between 270 and 320 °C.

## Inverter with open-drain output

74LVC1G06

## Suitability of surface mount IC packages for wave and reflow soldering methods

PACKAGE <sup>(1)</sup>	SOLDERING METHOD	
	WAVE	REFLOW <sup>(2)</sup>
BGA, LBGA, LFBGA, SQFP, TFBGA, VFBGA	not suitable	suitable
DHVQFN, HBCC, HBGA, HLQFP, HSQFP, HSOP, HTQFP, HTSSOP, HVQFN, HVSON, SMS	not suitable <sup>(3)</sup>	suitable
PLCC <sup>(4)</sup> , SO, SOJ	suitable	suitable
LQFP, QFP, TQFP	not recommended <sup>(4)(5)</sup>	suitable
SSOP, TSSOP, VSO, VSSOP	not recommended <sup>(6)</sup>	suitable

## Notes

1. For more detailed information on the BGA packages refer to the “(LF)BGA Application Note” (AN01026); order a copy from your Philips Semiconductors sales office.
2. All surface mount (SMD) packages are moisture sensitive. Depending upon the moisture content, the maximum temperature (with respect to time) and body size of the package, there is a risk that internal or external package cracks may occur due to vaporization of the moisture in them (the so called popcorn effect). For details, refer to the Drypack information in the “Data Handbook IC26; Integrated Circuit Packages; Section: Packing Methods”.
3. These packages are not suitable for wave soldering. On versions with the heatsink on the bottom side, the solder cannot penetrate between the printed-circuit board and the heatsink. On versions with the heatsink on the top side, the solder might be deposited on the heatsink surface.
4. If wave soldering is considered, then the package must be placed at a 45° angle to the solder wave direction. The package footprint must incorporate solder thieves downstream and at the side corners.
5. Wave soldering is suitable for LQFP, TQFP and QFP packages with a pitch (e) larger than 0.8 mm; it is definitely not suitable for packages with a pitch (e) equal to or smaller than 0.65 mm.
6. Wave soldering is suitable for SSOP, TSSOP, VSO and VSSOP packages with a pitch (e) equal to or larger than 0.65 mm; it is definitely not suitable for packages with a pitch (e) equal to or smaller than 0.5 mm.

## Inverter with open-drain output

74LVC1G06

## DATA SHEET STATUS

LEVEL	DATA SHEET STATUS <sup>(1)</sup>	PRODUCT STATUS <sup>(2)(3)</sup>	DEFINITION
I	Objective data	Development	This data sheet contains data from the objective specification for product development. Philips Semiconductors reserves the right to change the specification in any manner without notice.
II	Preliminary data	Qualification	This data sheet contains data from the preliminary specification. Supplementary data will be published at a later date. Philips Semiconductors reserves the right to change the specification without notice, in order to improve the design and supply the best possible product.
III	Product data	Production	This data sheet contains data from the product specification. Philips Semiconductors reserves the right to make changes at any time in order to improve the design, manufacturing and supply. Relevant changes will be communicated via a Customer Product/Process Change Notification (CPCN).

## Notes

1. Please consult the most recently issued data sheet before initiating or completing a design.
2. The product status of the device(s) described in this data sheet may have changed since this data sheet was published. The latest information is available on the Internet at URL <http://www.semiconductors.philips.com>.
3. For data sheets describing multiple type numbers, the highest-level product status determines the data sheet status.

## DEFINITIONS

**Short-form specification** — The data in a short-form specification is extracted from a full data sheet with the same type number and title. For detailed information see the relevant data sheet or data handbook.

**Limiting values definition** — Limiting values given are in accordance with the Absolute Maximum Rating System (IEC 60134). Stress above one or more of the limiting values may cause permanent damage to the device. These are stress ratings only and operation of the device at these or at any other conditions above those given in the Characteristics sections of the specification is not implied. Exposure to limiting values for extended periods may affect device reliability.

**Application information** — Applications that are described herein for any of these products are for illustrative purposes only. Philips Semiconductors make no representation or warranty that such applications will be suitable for the specified use without further testing or modification.

## DISCLAIMERS

**Life support applications** — These products are not designed for use in life support appliances, devices, or systems where malfunction of these products can reasonably be expected to result in personal injury. Philips Semiconductors customers using or selling these products for use in such applications do so at their own risk and agree to fully indemnify Philips Semiconductors for any damages resulting from such application.

**Right to make changes** — Philips Semiconductors reserves the right to make changes in the products - including circuits, standard cells, and/or software - described or contained herein in order to improve design and/or performance. When the product is in full production (status 'Production'), relevant changes will be communicated via a Customer Product/Process Change Notification (CPCN). Philips Semiconductors assumes no responsibility or liability for the use of any of these products, conveys no licence or title under any patent, copyright, or mask work right to these products, and makes no representations or warranties that these products are free from patent, copyright, or mask work right infringement, unless otherwise specified.

Inverter with open-drain output

74LVC1G06

---

**NOTES**

# ***Philips Semiconductors – a worldwide company***

## **Contact information**

For additional information please visit <http://www.semiconductors.philips.com>. Fax: +31 40 27 24825

For sales offices addresses send e-mail to: [sales.addresses@www.semiconductors.philips.com](mailto:sales.addresses@www.semiconductors.philips.com).

© Koninklijke Philips Electronics N.V. 2003

SCA75

All rights are reserved. Reproduction in whole or in part is prohibited without the prior written consent of the copyright owner.

The information presented in this document does not form part of any quotation or contract, is believed to be accurate and reliable and may be changed without notice. No liability will be accepted by the publisher for any consequence of its use. Publication thereof does not convey nor imply any license under patent- or other industrial or intellectual property rights.

Printed in The Netherlands

613508/04/pp16

Date of release: 2003 Mar 03

Document order number: 9397 750 10066

*Let's make things better.*

**Philips  
Semiconductors**



**PHILIPS**